

CAD FILE:

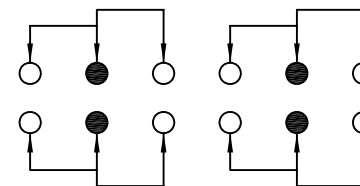

SCHEMATIC(NON-SHORTING)

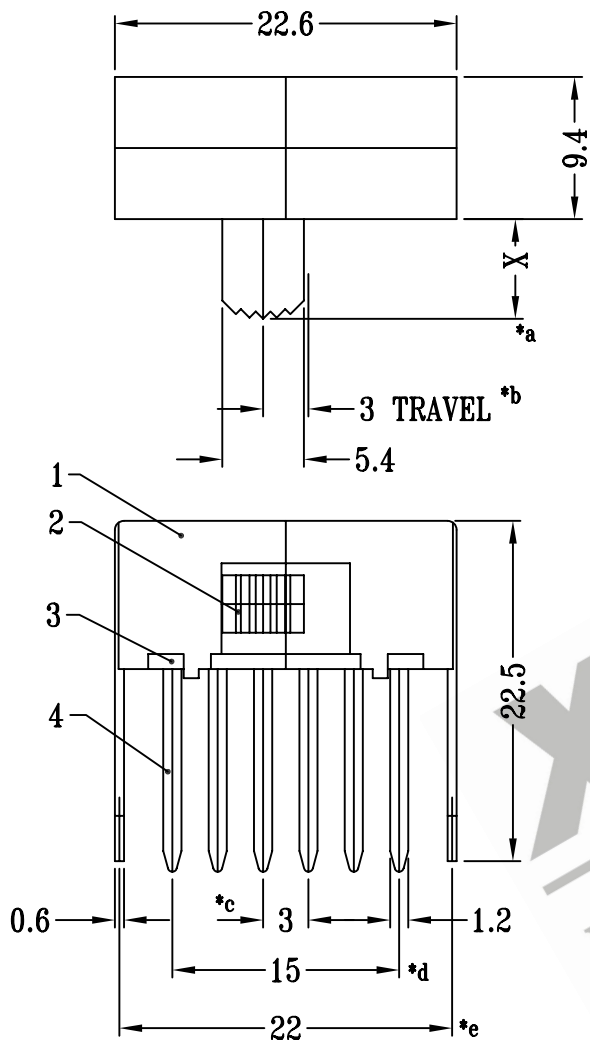
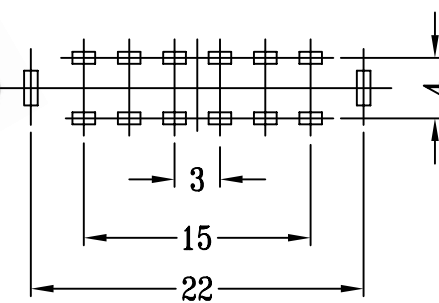
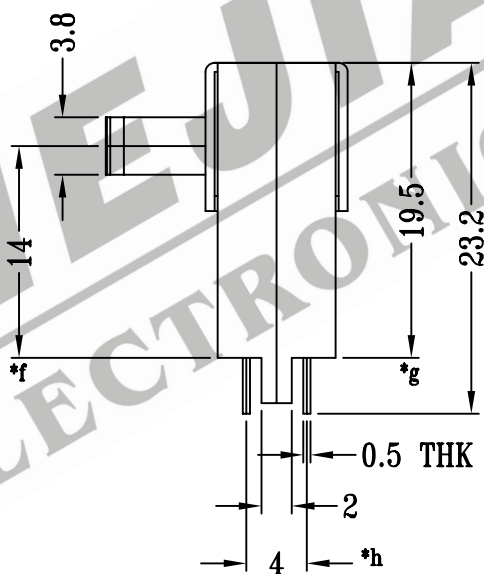

P.C.B LAYOUT

注:带"\*"表示关键尺寸(8个)

NO.	PARTS	MATERIALS	Q'TY	FINISH	TOLERANCE UNLESS SPECIFIED	SHENZHEN XIEJIA ELECTRONICS CO.,LTD.				
8						TITLE : HORIZONTAL SLIDE SWITCH	UNIT : mm	DRWG NO.: XJ-DR-SK42F02-00		
7	STEEL BALL	STEEL	1	NATURAL	WITHIN: 1.5±0.1mm OVER : 1.5±0.2mm			SCALE: 2:1	DWN.	ZHOUYU
6	SPRING	STEEL WIRE	1	TEMPER		MODEL: SK-42F02		CHK'D	FANGYING	2005-8-10
5	CONTACT CLIP	PBS STRIP	4	Ag PLATED		ALL MATERIALS MUST BE COMPLIANT TO ROHS		APPD.	KANGXINAN	2005-8-10
4	TERMINAL	BRASS STRIP	12	Ag PLATED OVER Ni PLATED						
3	BASE	PHENOLIC RESIN	1	NATURAL						
2	KNOB	POM	1	BLACK						
1	FRAME	STEEL STRIP	1	Ni PLATED						